

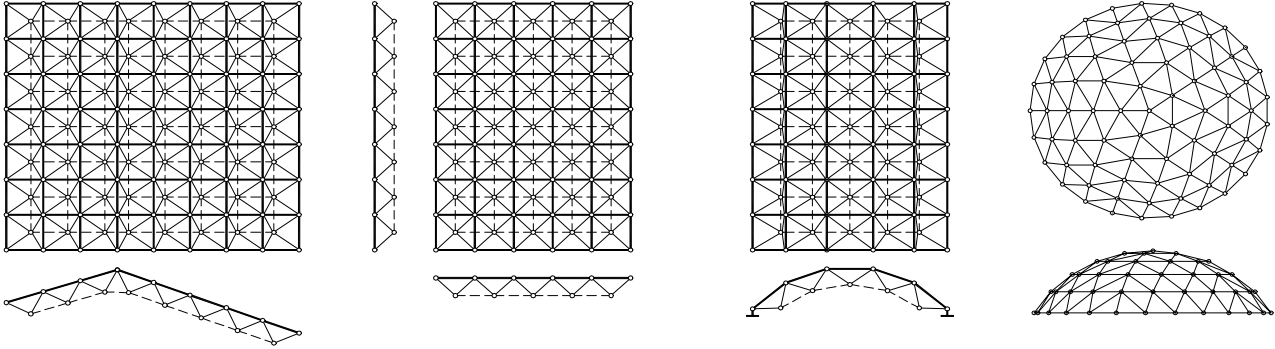

## SPACE FRAME SYSTEMS

- TRIANGULAR MODULES are efficient in transferring stresses. With little to no bending moments, they are more stable and stronger than 90 degree frames.



- 3-D LATTICE STRUCTURES can cover larger areas at a lower weight. The many lightweight members in a lattice structure distribute loads evenly and efficiently through the structure in three dimensions, making it more efficient and lighter than a conventional two-dimensional frame.

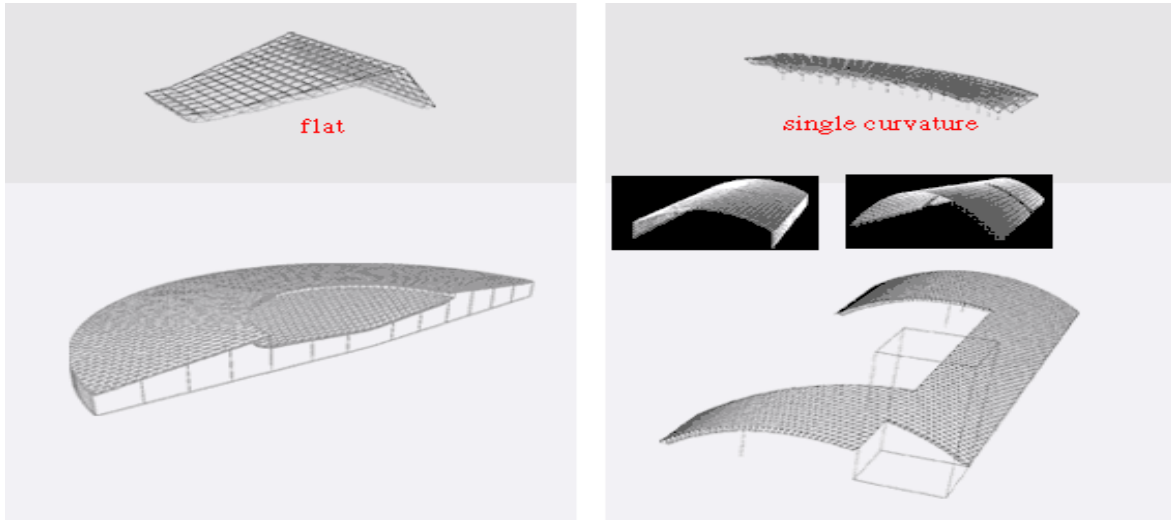

- DOUBLY CURVED GEOMETRIES have the ability to span long distances. Their curvature transfers stresses more efficiently with little to no bending moments, making them stiffer than conventional flat surfaces. Doubly curved geometries now offer infinite possibilities of free-style designs.

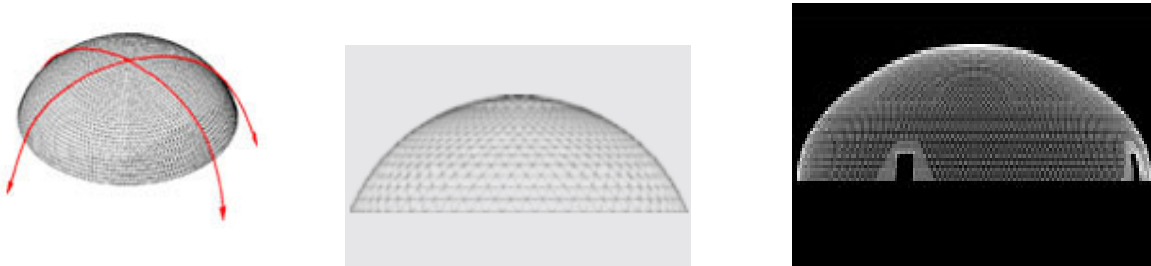



### APPLICATION FIELDS

- Industrial Structures (Factory, Warehouses, Antrepo, Hangar etc.)
- Spors Complexes(Swimming Pools, Sport hallsı,tribunes,etc.)
- Multipurpose Halls (Theatres,Concert Hallsı, Cinemas, Convention Centres, Exhibition Halls,etc.)
- Hangar Buildings, Canopies,Stands etc.
- Shopping centres ,showrooms , transportation structures , school structures,etc.

### ADVANTAGES

- Since the space frame systems can designed in 3d and can statically work in two sides big spans can be passed with acceptable system heights.
- For thermal effections its structure is more flexible than the other structures.
- Cantilevers can be easily applied to structure in both four sides..
- Uzay sistem içerisine klima havalandırma kanalları, tesisat ve elektrik kanalları, kedi yolları, aydınlatma sistemleri ve ışık köprüleri yerleştirilebilir.AC Ducts,electrical and colleteral canals ,catwalks,lightning systems can be easily hanged to space frames.

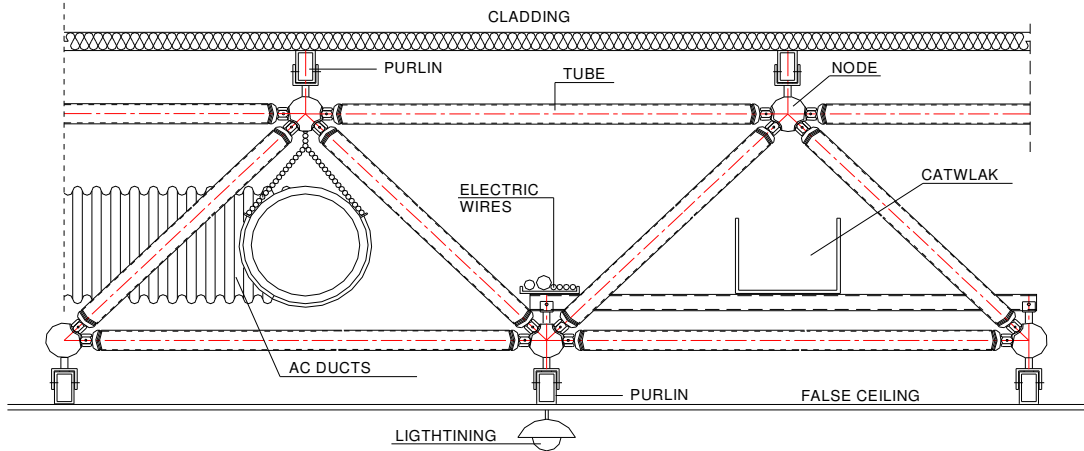

- System can be covered with all kind of cladding systems from outside and from inside false ceiling can be easily applied if necessary..
- Space Frame Systems are demontable .
- It can be easily transported by seafreight,trucks or air freight.
- Assembly of space frame systems are easy and quick.
- Can be either erected on ground or at sight by scaffoldings and cranes.

## SYSTEM DETAILS

### NODES

- Nodes are selected from  $\varnothing 50$  mm to  $\varnothing 400$  mm diametre shall be produced with C45 or AISI\SAE1050 quality material in confemance with the EN10083-2 standard.
- They are produced by hot forging or machining production techniques.
- All nodes shall be drilled and tapped by digitally controoled machines according to design calculations.

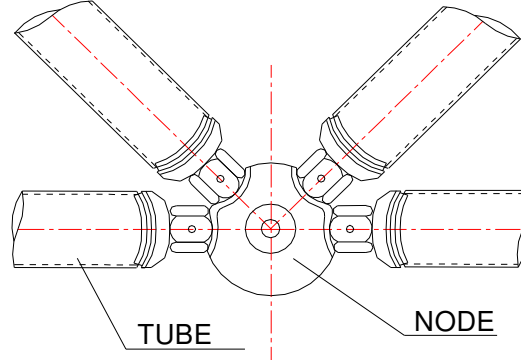

### TUBES

- All the tubes , whose sections are determined according to the tension and compression forces as per the design calculations can be both seamed or seamless tubes from S235JR (St 37-2), S275 JR(St 44-2), S355J2G3 (St 52-3) quality steel sheets with high weldability property confirming to EN10025 standards.
- Tubes produced in confemance to DIN 2440, DIN 2441, DIN 1626 , EN 10219 Standards are chosed from 26.9 mm to 324 mm according to the design calculations .
- Hot forged or machined cones of the same quality of the tubes are welded to each sides by semi automatic gas shielded arc welding process.

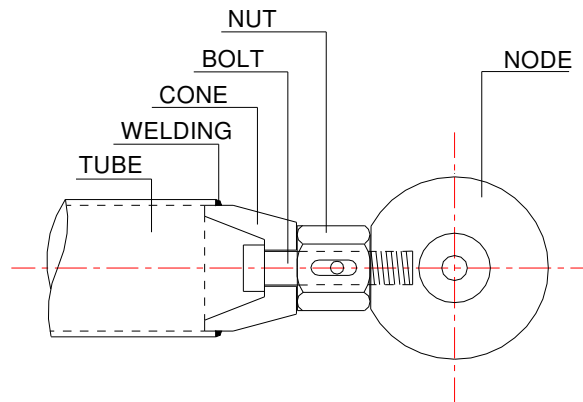

### BOLTS

- All bolts shall be produced in confarmance with EN 10083-1 standard and shall have isometric threads conforming to DIN 13-1.
- Strength classification shall be 6.8 , 8.8 , or 10,9 in compliance with the requirements of en20898-1 .

### NUTS

- All nuts shall be produced from hexagonal shaped cold and \ or hot rolled S355J2G3(St52-3)quality non alloyed steel and \ or AISI\SAE 1030 quality low alloyed steel.

### SUPPORTS

- Supports shall produced with C45 or AISI\SAE 1050 quality material in conformance with the EN 10083-2 standard with hot forging and\or machinind production techniques .
- All bolt connection holes are drilled and tapped by numerical controlled machines based on design calculations.
- Support flanges shall be of S235JR(St 37-2) material in conformance wit E10025.
- Teflon plates shall be placed under the moveable supports.

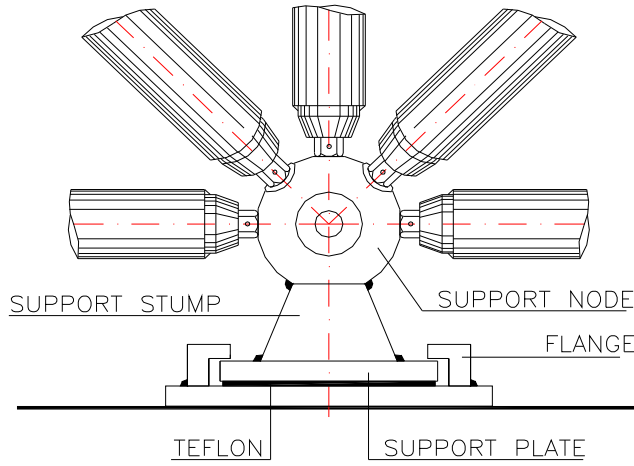

### PURLINS,PURLIN STOOLS

- Profiles that cladding is connected to are called purlins and assembled to space frame with stools in different heights based on slope and design calculations .
- They are selected from profiles with channel sections or box sections or build-up sections and can be in same or different colour with space frame.

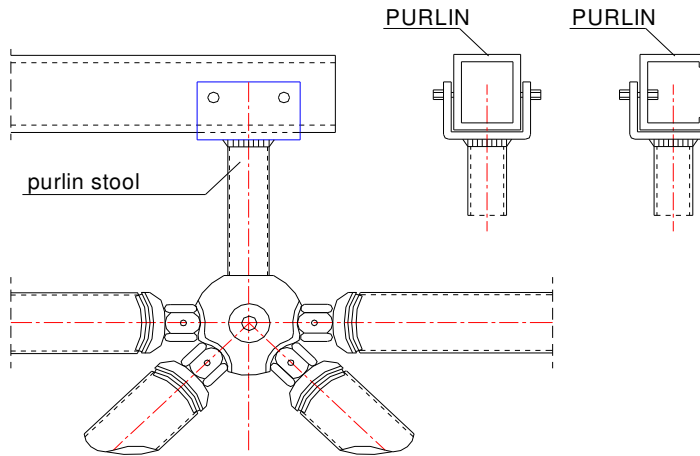

- Purlins shall be of S235JR(St 37-2) material in conformance wit E10025.
- Slope of the roof shall be provided with means of purlin stools .

- Connection of the purlin stools to the nodes shall be made by bolts .
- Purlin stools shall be of S235JR(St 37-2) material in conformance wit E10025.

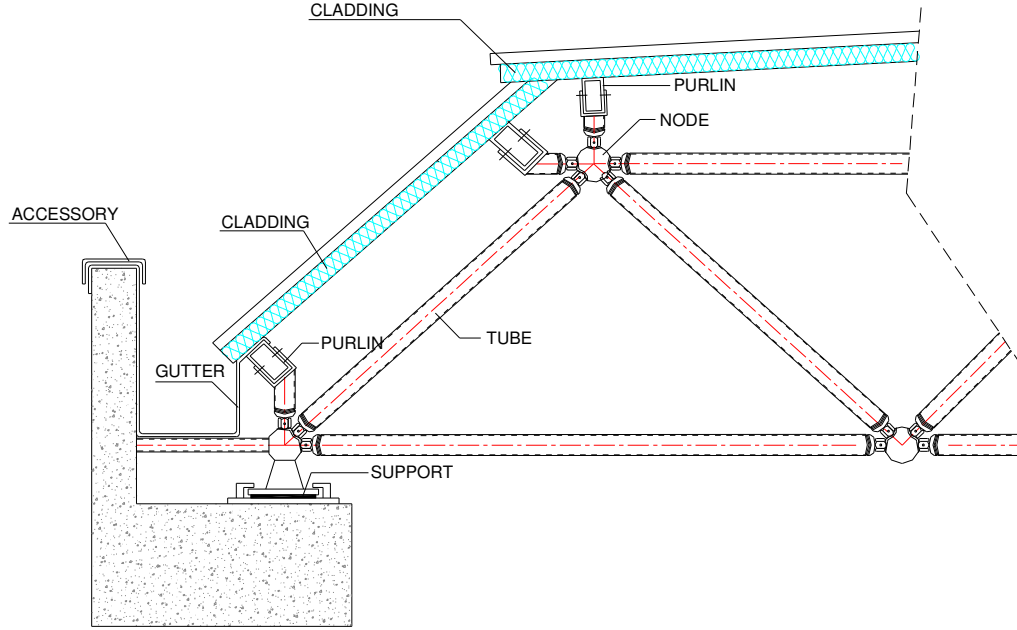

### PROTECTION AGAINST CORRESION

- Space Frame elements protection against corresion can be arranged by ;
  1. Galvanizing
    - Hot Dipped Galvanizing
    - Electro galvanizing
  2. Paint
    - Electrostatic Powder Paint
    - Wet Paint
- Tubes ,purlins and purlin stools are first cleaned in acid tanks to remove rust away and than shall receive electrostatic polyester powder coating of avarage 70-80 microns and shall be baked in oven at 200 °C .
- If required tubes and purlins can be hot dipped galvanized in conformance with EN 1179 prior to powder coating.
- Nodes ,Bolts and Supports shall be electro plated with avarage 25 micron zinc in conformance with ISO 20081.
- SIlves shall be hot dipped galvanized in conformance with EN 1179 .

### ERECTION

Prior to erection general site conditions and condition of the structure on which space frame is to be erected shall be checked by an engineer of UZAY KONSTRUKSİYON Engineer and unsatisfactory conditions are reported to main contarctor to allow to start erection .

Erection shall be done strictly acoording to approved shop drawings.

Erection shall be done by professional erection crews based on Uzay Konstruksiyon Engineers instructions.

Erection can be done both on ground and lifted by cranes or at sight with helps of scaffoldings.

All bolts shall be correctly tightened .

All supports shall be correctly placed and rotated based on shop drawings.

Site welds of the supports shall be done by certified welders.